

DIMENSIONS ARE TO BE USED AS GUIDE TO THE GENERAL PROPORTION OF THE DOOR. CONTRACTOR TO VERIFY ALL EXISTING CONDITIONS AND DIMENSIONS AND MAKE ADJUSTMENTS AS REQUIRED

1 EXTERIOR DOOR ELEVATION
SCALE: 3/4" = 1'-0"

GENERAL NOTES:

THIS DRAWING ILLUSTRATES THE PERCEIVED ORIGINAL DESIGN INTENT OF THE DOOR TYPE NOTED BELOW, AND IS TO BE REFERENCED ONLY AS A GUIDE IN PREPARATION OF FABRICATION DRAWINGS FOR DOOR REPLACEMENT. VERIFICATION OF ALL EXISTING SITE CONDITIONS, DIMENSIONS AND APPLICABLE CODES IS THE RESPONSIBILITY OF THE FABRICATOR, INSTALLER OR OWNER. ALL PERFORMANCE CRITERIA AND OPERATIONAL CHARACTERISTICS ARE TO BE DETERMINED BY THE OWNER. THIS DRAWING IS NOT FOR CONSTRUCTION.

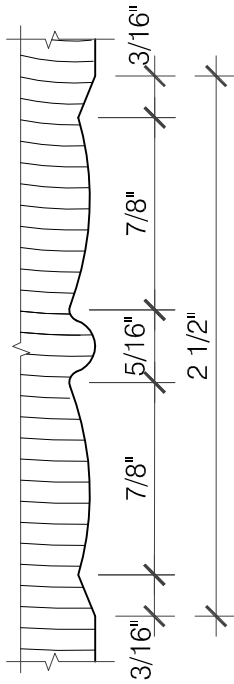

7 SCROLL DETAIL
SCALE: 1'-0" = 1'-0"

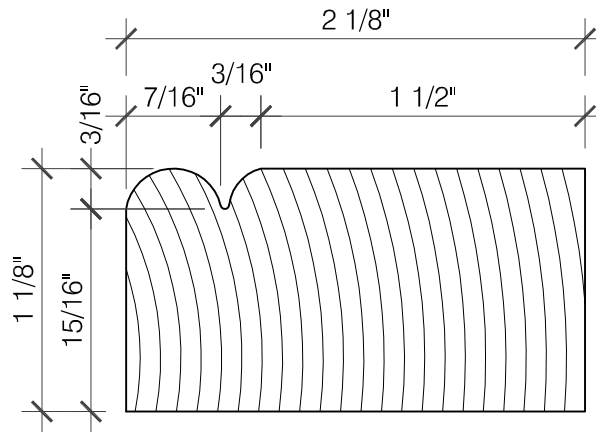

4A BRICK MOLD DETAIL
SCALE: 1'-0" = 1'-0"

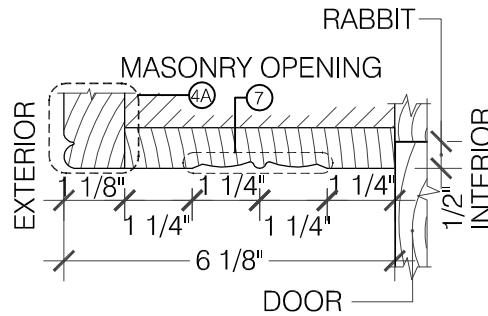

4 SECTION AT BRICK MOLD AND JAMB
SCALE: 3" = 1'-0"

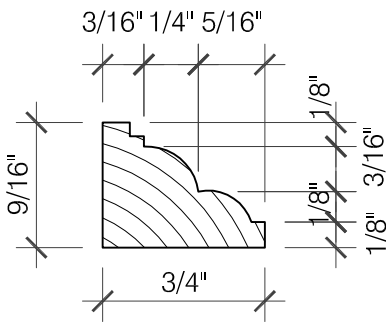

6 PANEL STOP DETAIL
SCALE: 1'-0" = 1'-0"

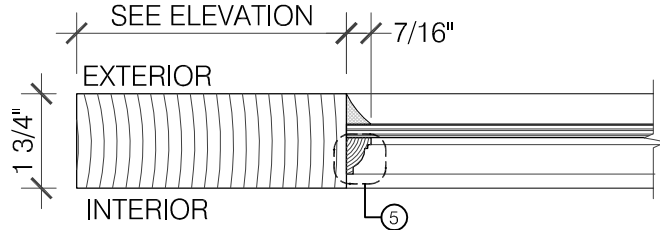

3 SECTION AT STILE/RAIL AND GLASS
SCALE: 3" = 1'-0"

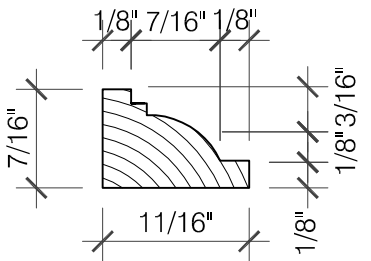

5 GLASS STOP DETAIL
SCALE: 1'-0" = 1'-0"

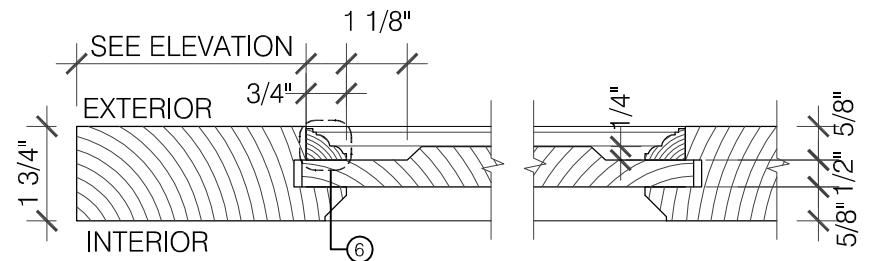

2 SECTION AT STILE/RAIL AND PANEL
SCALE: 3" = 1'-0"

GENERAL NOTES:

THIS DRAWING ILLUSTRATES THE PERCEIVED ORIGINAL DESIGN INTENT OF THE DOOR TYPE NOTED BELOW, AND IS TO BE REFERENCED ONLY AS A GUIDE IN PREPARATION OF FABRICATION DRAWINGS FOR DOOR REPLACEMENT. VERIFICATION OF ALL EXISTING SITE CONDITIONS, DIMENSIONS AND APPLICABLE CODES IS THE RESPONSIBILITY OF THE FABRICATOR, INSTALLER OR OWNER. ALL PERFORMANCE CRITERIA AND OPERATIONAL CHARACTERISTICS ARE TO BE DETERMINED BY THE OWNER. THIS DRAWING IS NOT FOR CONSTRUCTION.