

GENERAL NOTES:

THIS DRAWING ILLUSTRATES THE PERCEIVED ORIGINAL DESIGN INTENT OF THE PORCH TYPE NOTED BELOW, AND IS TO BE REFERENCED ONLY AS A GUIDE IN PREPARATION OF FABRICATION DRAWINGS FOR PORCH REPLACEMENT. VERIFICATION OF ALL EXISTING SITE CONDITIONS, DIMENSIONS AND APPLICABLE CODES IS THE RESPONSIBILITY OF THE FABRICATOR, INSTALLER OR OWNER. ALL PERFORMANCE CRITERIA AND OPERATIONAL CHARACTERISTICS ARE TO BE DETERMINED BY THE OWNER. THIS DRAWING IS NOT FOR CONSTRUCTION.

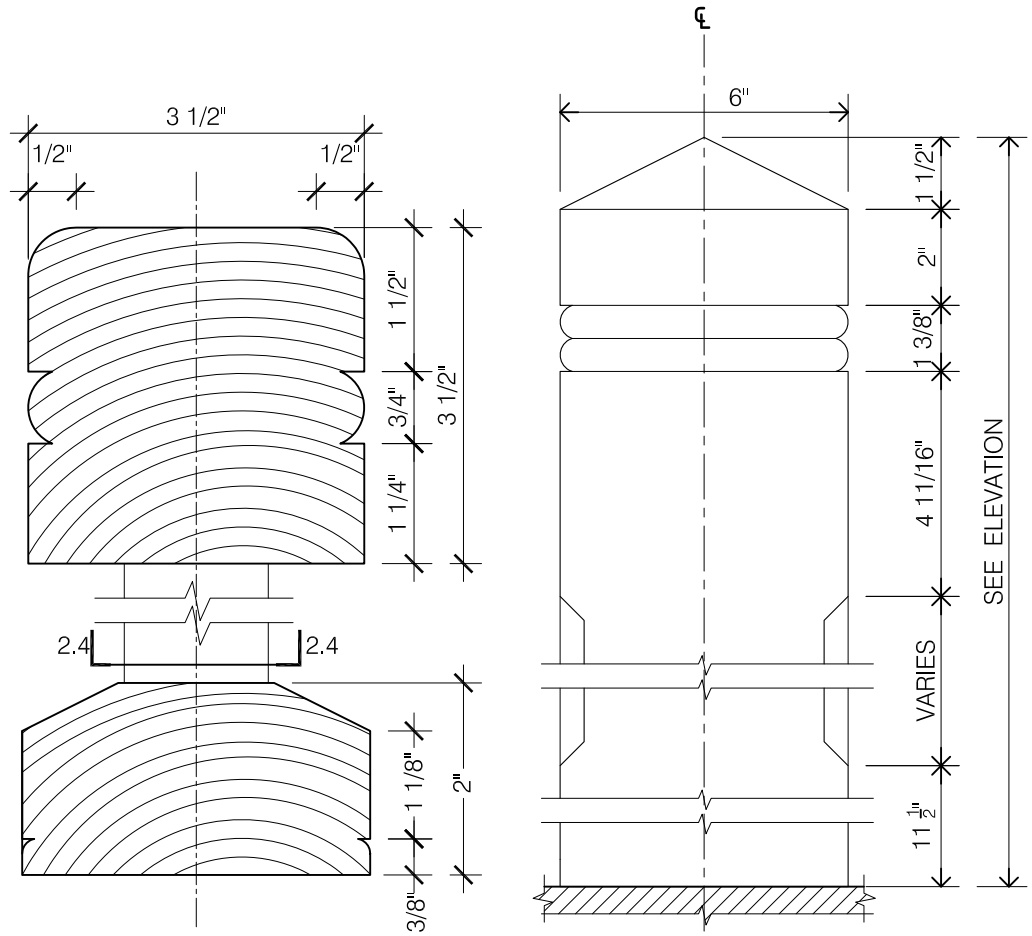

2.4 SECTION THROUGH TYPICAL SPINDLE
SCALE: 3" = 1'-0"

2.3 SECTION AT HAND RAIL
SCALE: 3" = 1'-0"

2.2 NEWEL POST DETAIL
SCALE: 3" = 1'-0"

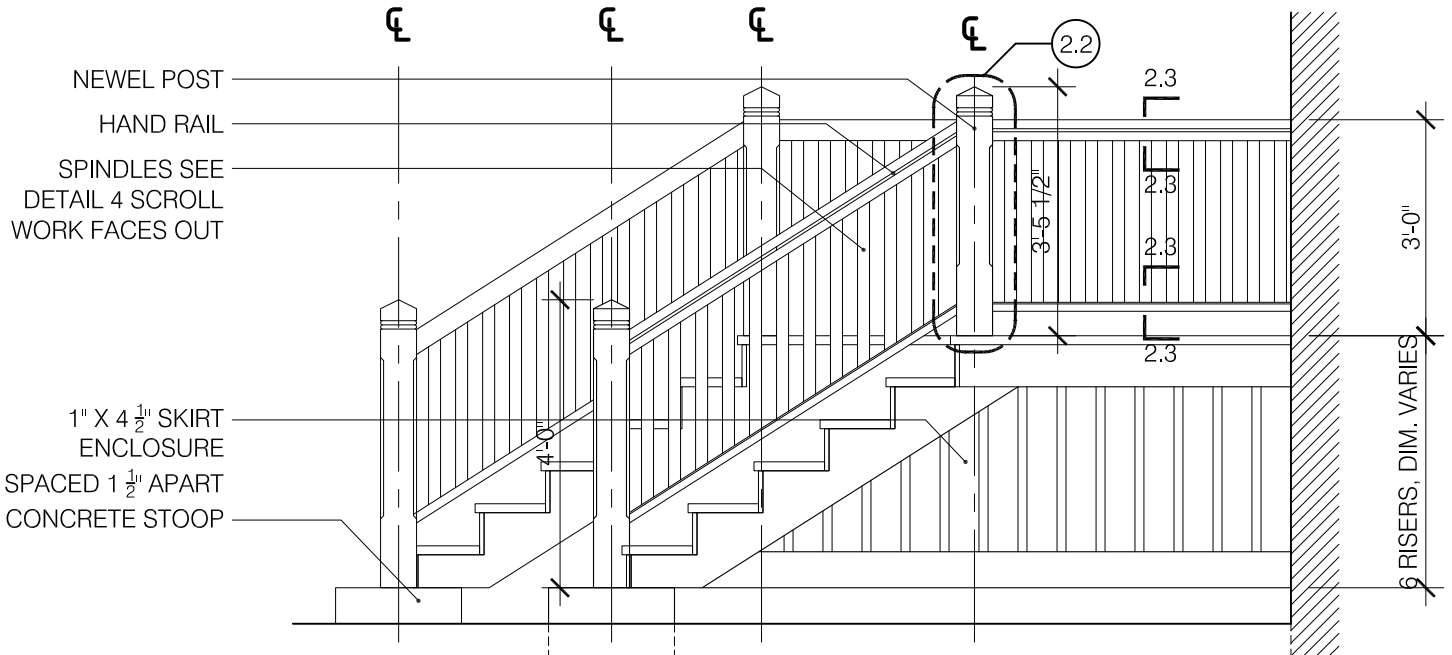

2.1 SIDE ELEVATION
SCALE: 3/8" = 1'-0"

GENERAL NOTES:

THIS DRAWING ILLUSTRATES THE PERCEIVED ORIGINAL DESIGN INTENT OF THE PORCH TYPE NOTED BELOW, AND IS TO BE REFERENCED ONLY AS A GUIDE IN PREPARATION OF FABRICATION DRAWINGS FOR PORCH REPLACEMENT. VERIFICATION OF ALL EXISTING SITE CONDITIONS, DIMENSIONS AND APPLICABLE CODES IS THE RESPONSIBILITY OF THE FABRICATOR, INSTALLER OR OWNER. ALL PERFORMANCE CRITERIA AND OPERATIONAL CHARACTERISTICS ARE TO BE DETERMINED BY THE OWNER. THIS DRAWING IS NOT FOR CONSTRUCTION.